

APPLICATION:

Pour un éclairage en sécurité dans des zones 1, 2, 21 and 22 (gaz et poussière).

FICHE TECHNIQUE 20/12/2023

Ce performant projecteur est utilisable :

- pour un éclairage sur véhicule
- pour un éclairage optimal sur cuves process , réservoirs, agitateurs ou réacteurs...
- combiné à un hublot de regard

compatible en montage sur hublot à brides DIN28120 ou dérivé, et autres hublots MV DIN11851

Technologie LED garantie une consommation électrique faible, et une durée de vie prolongée. Blanc froid

INDICE DE PROTECTION:

IP 65 et IP 67 suivant DIN EN 60529

TEMPERATURE DE SERVICE:

-20°C à 50°C

PROTECTION NORME ATEX: Conforme à la directive 2014/34/EU

Ce projecteur est particulièrement adapté aux exigences normatives :

Gaz	
EN IEC 60079-0:2018	General Requirements
EN 60079-1:2014	Flame-proof Enclosures „d“
EN IEC 60079-7:2015 + A1:2018	Increased Safety „e“
Explosion group	IIC (includes IIA and IIB)
Classe température	T6

Poussière	
EN IEC 60079-0:2018	General Requirements
EN 60079-31:2014	Protection by Enclosures „t“
Explosion group	IIIC (includes IIIA and IIIB)
Classe température	T80°

EU-Type Examination Certificate:

BVS 08 ATEX E 135

II 2G Ex db eb IIC T6 Gb

II 2D Ex tb IIIC T80°C Db



Tension	Puissance	intensité lumineuse	temp.couleur	angle diffusion	information	Part no.
12 V/24 V DC	9 W	450-500 lm	6500 K blanc froid	12°		3542.230.00
12 V/24 V DC	9 W	450-500 lm	6500 K blanc froid	25°		3542.231.00
12 V/24 V DC	9 W	450-500 lm	6500 K blanc froid	38°		3542.232.00
12 V/24 V DC	9 W	450-500 lm	6500 K blanc froid	12°	pastille LED scellée	3542.233.00
24 V AC/DC	14 W	450-500 lm	6500 K blanc froid	12°		3542.235.00
24 V AC/DC	14 W	450-500 lm	6500 K blanc froid	25°		3542.236.00
24 V AC/DC	14 W	450-500 lm	6500 K blanc froid	38°		3542.237.00
220-240 V AC	7 W	suivant type de lampe			socket GU10	3542.245.00

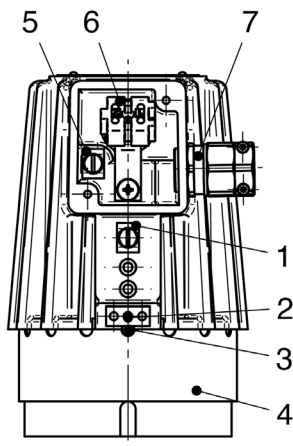

- 1 Protection terre boîtier
- 2 vis verrou
- 3 verrou blocage
- 4 verrine verre
- 5 protection interne
- 6 Ex connection alim.
- 7 Presse étoupe M20 x 1.5

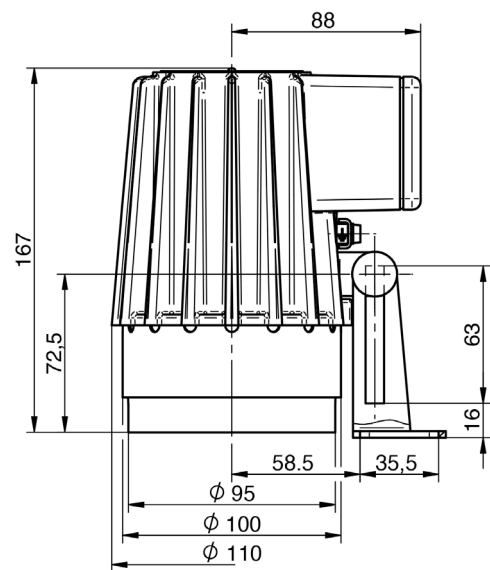

ASSEMBLAGE:

En utilisation sur un hublot circulaire type DIN28120 ou dérivé, avec sa charnière de fixation via une vis M8.

Possibilité de montage sans charnière via un manchon de fixation usiné, généralement sur hublot type MV (uniquement éclairage)

CONNECTION ELECTRIQUE:

Presse étoupe entrée variable (droite ou gauche).

Livré sans câble. Câble diamètre: 8-15 mm

POIDS :

2.1 kg

Matériels	
Corps du projecteur	Aluminium
verre verrine	Borosilicate
charnière de fixation	Stainless steel
joint d'étanchéité boîtier	Viton

Accessoires	Part no.
charnière de fixation, stainless steel	0354.016.00
manchon d'adaption (nous contacter)	
LED angle 12°	3511.008.00
LED angle 25°	3511.009.00
LED angle 38°	3511.010.00

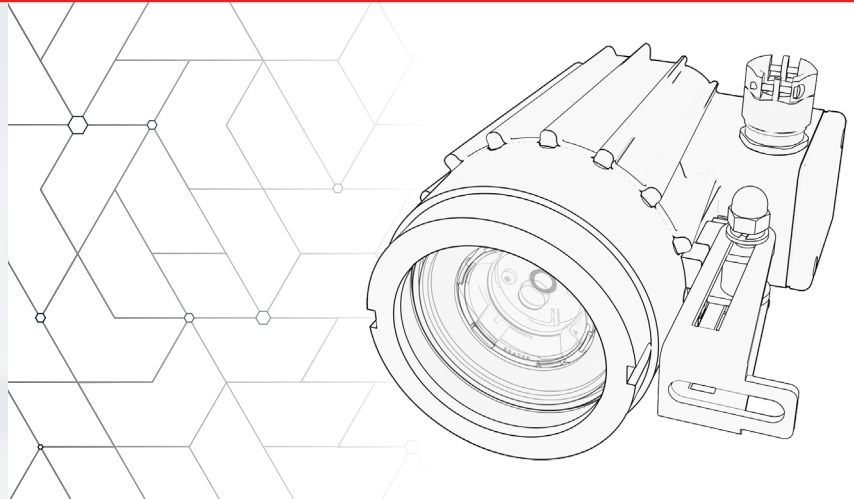
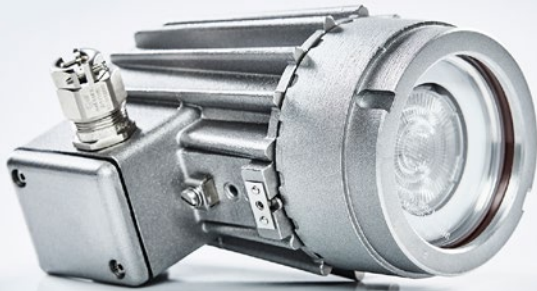

APPLICATION:

For safe use in potentially explosive environments in zones 1, 2, 21 and 22 (gas and dust).

This Lumistar variant impresses with its versatility:

- as a vehicle luminaire
- for the optimal illumination of closed vessels, boilers, tanks, silos, agitators and reactors.
- in combination with flow sight glasses

For use with circular sight glass fittings to DIN 28120/DIN 28121 or similar, with screw-type sight glass fittings in compliance with DIN 11851, and in visual flow indicators.

Trend-setting LED technology guarantees even lower energy consumption, longer service life and flexible light colour.

PROTECTION:

IP 65 and IP 67 to DIN EN 60529

AMBIENT TEMPERATURES:

-20°C to 50°C

TECHNICAL DATA EX PROTECTION:

Approval according to Directive 2014/34/EU

This luminaire meets the essential safety and health requirements by complying with the regulations for:

Gas	
EN IEC 60079-0:2018	General Requirements
EN 60079-1:2014	Flame-proof Enclosures „d“
EN IEC 60079-7:2015 + A1:2018	Increased Safety „e“
Explosion group	IIC (includes IIA and IIB)
Temperature class	T6

Dust	
EN IEC 60079-0:2018	General Requirements
EN 60079-31:2014	Protection by Enclosures „t“
Explosion group	IIIC (includes IIIA and IIIB)
Temperature class	T80°

EU-Type Examination Certificate:
BVS 08 ATEX E 135

II 2G Ex db eb IIC T6 Gb
 II 2D Ex tb IIIC T80°C Db

Voltage	Nominal power	Nominal luminous flux	Light colour*	Beam angle	Addition	Part no.
12 V/24 V DC	9 W	450-500 lm	6500 K cold white	12°		3542.230.00
12 V/24 V DC	9 W	450-500 lm	6500 K cold white	25°		3542.231.00
12 V/24 V DC	9 W	450-500 lm	6500 K cold white	38°		3542.232.00
12 V/24 V DC	9 W	450-500 lm	6500 K cold white	12°	including sealing plug	3542.233.00
24 V AC/DC	14 W	450-500 lm	6500 K cold white	12°		3542.235.00
24 V AC/DC	14 W	450-500 lm	6500 K cold white	25°		3542.236.00
24 V AC/DC	14 W	450-500 lm	6500 K cold white	38°		3542.237.00
220-240 V AC	7 W	depending on the lamp type			socket GU10	3542.245.00

*other light colours on request

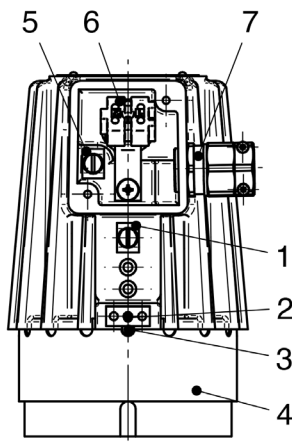

- 1 Protective conductor terminal outside
- 2 Locking screw
- 3 Locking lug
- 4 Screw glass
- 5 Internal protective conductor terminal
- 6 Ex terminals
- 7 Cable gland M20 x 1.5

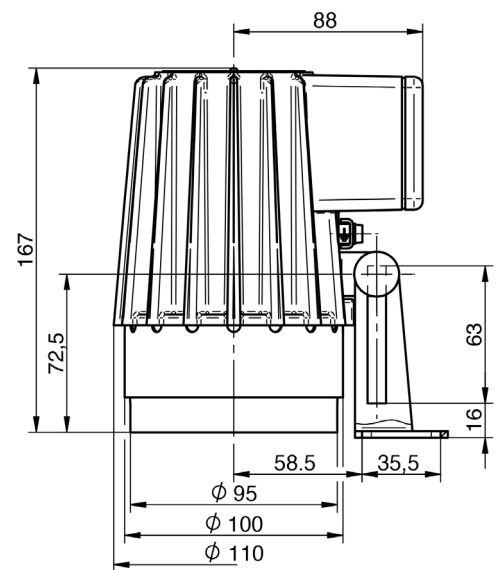

FIXING:

In the case of a round sightglass fitting and a visual flow indicators, the luminaire is fixed to the cover flange with the mounting bracket. With a screw-in sightglass fitting, the luminaire is fixed on the slotted cover nut, alternatively via a flanged adapter collar or a mounting bracket.

ELECTRICAL CONNECTION:

Cable entry variable (right or left). The unused opening is closed with a sealing plug. Cable lengths: any Cable diameter: 8-15 mm

NOMINAL WIDTHS:

For round sightglasses similar to DIN 28120, DIN 28121 and flow sightglasses, fixing on cover flange: from DN 50.

For screwed sightglasses similar to DIN 11851, fixing on or under the slotted cover nut:
 DN 65, 80, 100: via flanged adapter collar
 DN 80, 100, 125: via mounting bracket
 DN 80, 100: via flanged adapter collar or mounting bracket

WEIGHT:

2.1 kg including connection box

Materials	
Luminaire body	Aluminium
Glass	Borosilicate
Mounting parts	Stainless steel
Flat gasket terminal box	Viton

Additional equipment	Part no.
Luminaire fixing mounting bracket, stainless steel	0354.016.00
Luminaire fixing flanged adapter collar, stainless steel	1356.015.00
LED lens 12°	3511.008.00
LED lens 25°	3511.009.00
LED lens 38°	3511.010.00
Assembly spanner for screwed sight glass	6805.001.00

Order specifications (example):

Part no. 3542.232.00: Lumistar luminaire USL 06LED Ex,

12 V/24 V DC, 9 W, beam angle 38°

Part no. 1356.015.00: Luminaire flanged adapter collar